



**GOVERNMENT OF GOA  
DIRECTORATE OF HEALTH SERVICES,  
PRIMARY HEALTH CENTRE, SIOLIM,  
Phone: 0832-2272687**

No: PHCS/NOC-Const/20-21/ 2371

DATE: 20/01/2021

**Provisional N.O.C. from sanitation point of view for Proposed Amalgamation of Plots, Construction of Residential Villas (15 nos.) & Compound Wall.**

With reference to your letter No. Nil dated 15/01/2021, it is to inform you that this Primary health centre has NO OBJECTION to issue NOC from the SANITARY POINT OF VIEW for proposed amalgamation of plots, construction of Residential Villas (15 nos.) & Compound Wall as per TCP order No.TPB/4158/SIO/TCP-21/206 dated 13/01/2021 on property bearing survey No. **242/15, 16, 17, 20, 21, 23, 25 & 29** plot no.**nil**, Siolim, Bardez-Goa, subject to the following conditions:

1. The construction shall be carried out as per the approved plan submitted.
2. The STP shall be at a distance of more than 15 meters from the existing well if any.
3. Proper cleanliness and sanitation should be maintained at the construction site.
4. No health hazard or any other environmental pollution shall be created in the surrounding area.
5. The owner/contractor shall co-operate with the Health and Pollution Control Authorities whenever they visit the site for inspection.
6. As per section 75 A of Goa Public Health Act all labourers shall possess valid health cards, renewable every three months from its date of issue. Whosoever contravenes the above provision shall be fined Rs.10000/- per labourer Health cards should be available at the site for inspection.
7. All Sanitary facilities (Toilet/Soak pit for proper disposal of waste water, Mosquito nets) should be provided to the labourers at the construction site.
8. Adequate anti-larval measures shall be carried out at the construction site in consultation with the health authority.
9. The owner/contractor shall display the signboard at the site with details such as name of the Proprietor/Builder/Contractor, NOC details obtained from the various appropriate Authorities.
10. Consent to establish the STP from Goa State Pollution Control Board should be submitted within three months from the date of issue of this NOC.
11. The consent to operate STP should be submitted during the final NOC for occupancy.
12. This office is not responsible for any court Litigation regarding the ownership and area of the property.
13. The N.O.C. is valid for three months & liable to be withdrawn if the conditions stipulated above are not complied with.

*SLSH*  
(Dr. Sachana Shetye)  
**HEALTH OFFICER**  
**PRIMARY HEALTH CENTER**  
**SIOLIM**

To,

M/s. M. V. R. Seaview Homes Pvt. Ltd,

Caranzalem,

Tiswadi,

Bardez-Goa.

Copy to:-

1. The Sarpanch/Secretary, V.P. Siolim-Sodiem, Bardez-Goa.
2. Office file.



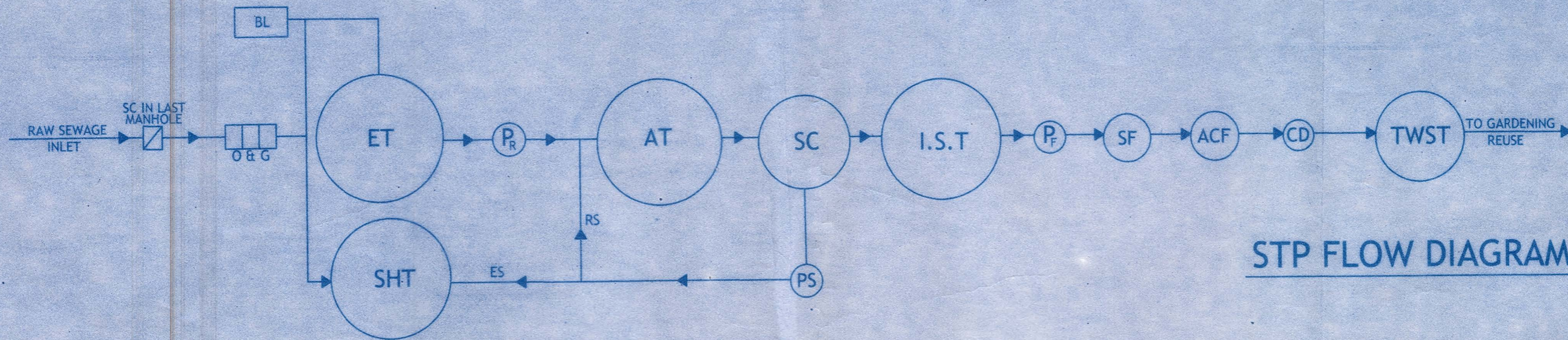

**STP FLOW DIAGRAM**

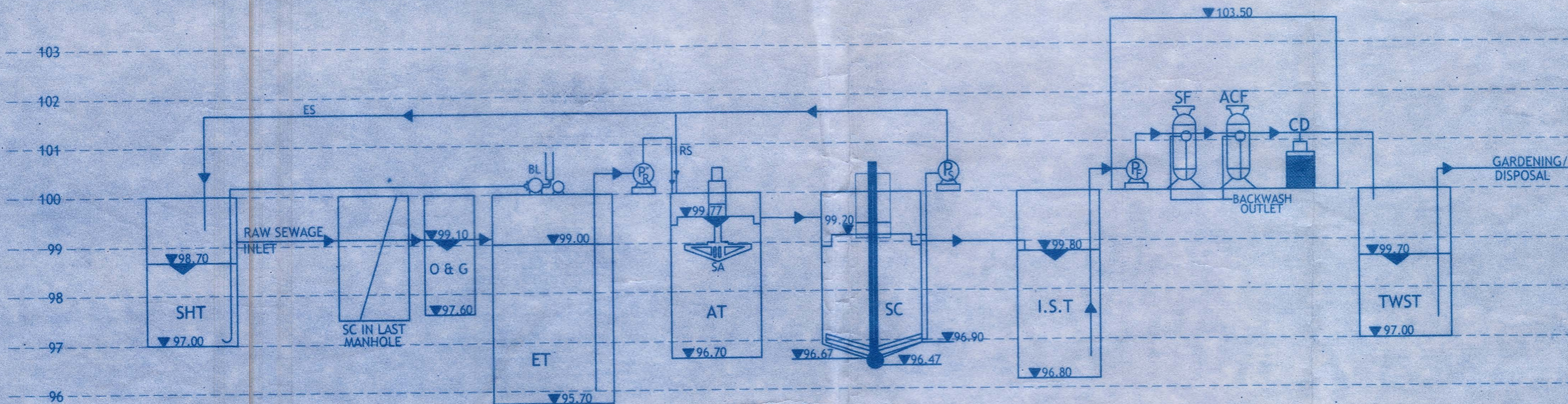

**HYDRAULIC DIAGRAM**

**LEGEND:**

- O & G: OIL AND GREASE TANK
- ET: EQUALIZATION TANK
- AT: AERATION TANK
- SC: SECONDARY CLARIFIER
- IST: INTERMEDIATE STORAGE TANK
- SF: SAND FILTER
- CD: CHLORINE DOSER
- SHT: SLUDGE HOLDING TANK
- TWST: TREATED WATER STORAGE TANK
- P<sub>R</sub>: RAW SEWAGE PUMP
- P<sub>S</sub>: SLUDGE PUMP
- P<sub>F</sub>: FILTER FEED PUMP

- SA : SURFACE AERATOR
- BL: BLOWER
- SF: SLUDGE FILTRATE
- RS: RETURN SLUDGE
- ES: EXCESS SLUDGE
- EFFLUENT LINE
- SLUDGE LINE
- AIR LINE
- BACKWASH OUTLET
- SLUDGE FILTRATE

NOTE: \*INVERT LEVEL IS 1.0M BELOW FGL  
\*ALL LEVELS ARE IN METERS.



**SEWAGE TREATMENT PLANT**

ARCHITECT'S SIGNATURE

Bryan J. Soares  
Reg. No. CA 35/12085  
AR/0031/2010

CLIENT'S SIGNATURE

MVR SEAVIEW HOMES PVT. LTD.

AUTHORISED SIGNATORY

ARCHITECTS:  
**SOARES & ASSOCIATES**

G-1, VIKAS BUILDING,  
18TH JUNE ROAD,  
PANJIM, GOA.

PH./FAX : 2228040 , 2430010/6642040  
e-mail: soares88@gmail.com